

+1.8V Low Power, Quad Input, 16-Bit Sigma-Delta A/D Converter with a Power Fault Monitor

Features

- 16-bit Resolution at Eight Conversions Per Second, Adjustable Down to 10-bit Resolution at 512 Conversions Per Second
- 1.8V – 5.5V Operation, Low Power Operating 280 μ A; Sleep: 37 μ A
- Two Differential and Two Single-ended Inputs with Built-in Multiplexer
- microPort™ Serial Bus Requires only two Interface Lines
- Uses Internal or External Reference
- Automatically Enters Sleep Mode when not in use
- Early Warning Power Fail Detector, also suitable as Wake-Up Timer Operational in Shutdown Mode

Applications

- Consumer Electronics, Thermostats, CO Monitors, Humidity Meters, Security Sensors
- Embedded Systems, Data Loggers, Portable Equipment
- Medical Instruments

Device Selection Table

| Part Number | Package | Temperature Range |
|-------------|----------------------|-------------------|
| TC3404VPE | 16-Pin PDIP (Narrow) | 0°C to +85°C |
| TC3404VQR | 16-Pin QSOP Narrow) | 0°C to +85°C |

Package Type

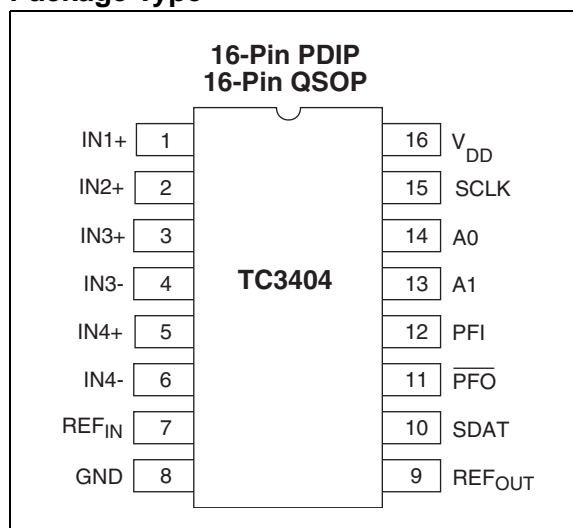

General Description

The TC3404 is a low cost, low power analog-to-digital converter based on Microchip's Sigma-Delta technology. It will perform 16-bit conversions (15-bit plus sign) at up to eight per second. The TC3404 is optimized for use as a microcontroller peripheral in low cost, battery operated systems. A voltage reference is included, or an external reference can be used.

The TC3404's 2-wire microPort™ digital interface is used for starting conversions and for reading out the data. Driving the SCLK line low starts a conversion. After the conversion starts, each additional falling edge (up to six) detected on SCLK for t_4 seconds reduces the A/D resolution by one bit and cuts conversion time in half. After a conversion is completed, clocking the SCLK line puts the MSB through LSB of the resulting data word onto the SDAT line, much like a shift register. The part automatically sleeps when not performing a data conversion.

The TC3404 is available in a 16-Pin PDIP and a 16-Pin QSOP package.

TC3404

Typical Application

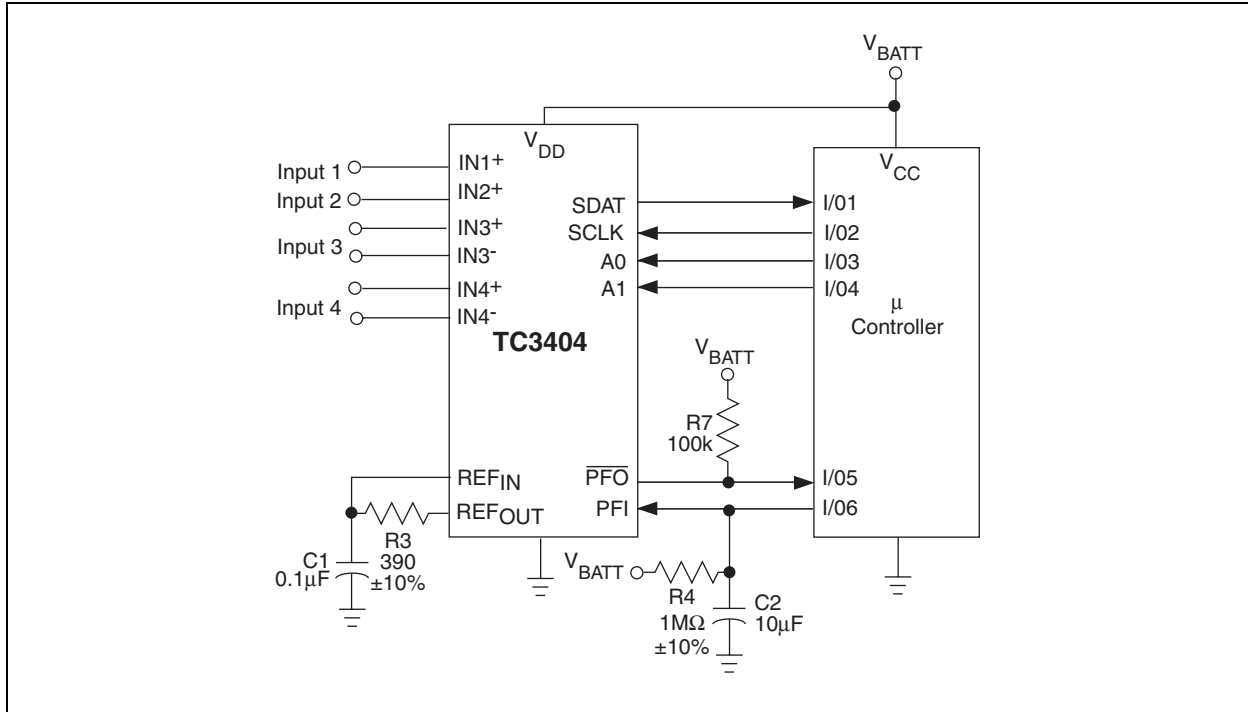

Functional Block Diagram

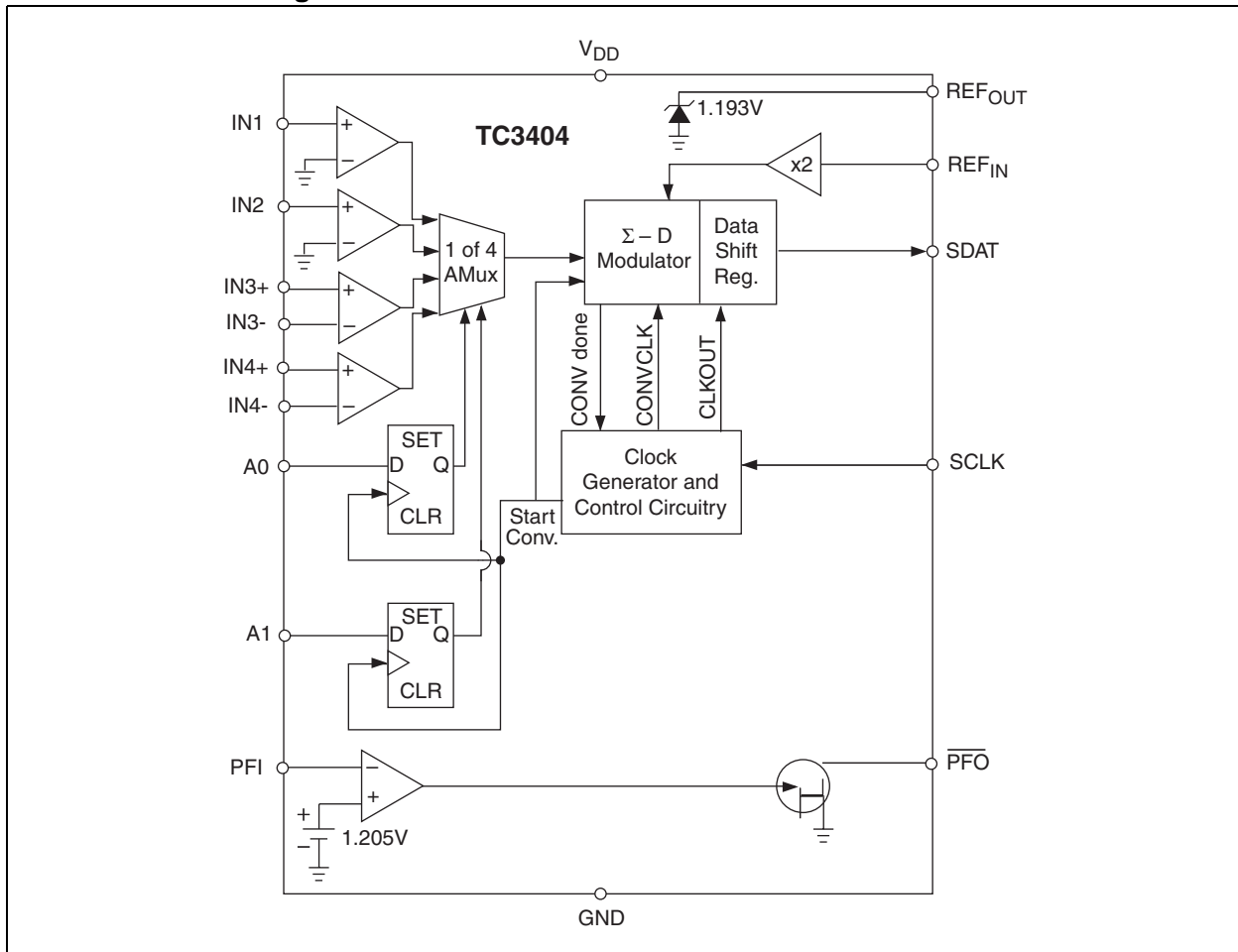

1.0 ELECTRICAL CHARACTERISTICS

Absolute Maximum Ratings*

| | |
|-----------------------------------|------------------------------------------|
| Supply Voltage | 6.0V |
| Voltage on Pin: | |
| PFO | GND – 0.3V) to 5.5V |
| Input Voltage (All Other Pins): | |
| | (GND – 0.3V) to (V _{DD} + 0.3V) |
| Operating Temperature Range | 0°C to 85°C |
| Storage Temperature | 65°C to +150°C |

*Stresses above those listed under "Absolute Maximum Ratings" may cause permanent damage to the device. These are stress ratings only and functional operation of the device at these or any other conditions above those indicated in the operation sections of the specifications is not implied. Exposure to Absolute Maximum Rating conditions for extended periods may affect device reliability.

TC3404 DC ELECTRICAL SPECIFICATIONS

Electrical Characteristics: T_A = 25°C and V_{DD} = 2.7V, unless otherwise specified. **Boldface** type specifications apply for temperatures of 0°C to 85°C. V_{REF} = 1.25V, Internal Clock Frequency = 520kHz.

| Symbol | Parameter | Min | Typ | Max | Unit | Test Conditions |
|--------------------------------------------|----------------------------------------------|-----|-----------|-----------------|-------|--------------------------------|
| Power Supply | | | | | | |
| V _{DD} | Supply Voltage | 1.8 | — | 5.5 | V | |
| I _{DD} | Supply Current, During Data Conversion | — | 280 | — | μA | |
| I _{DDSLLEEP} | Supply Current, Sleep Mode | — | 37 | 50 | μA | T _A = +25°C |
| | | — | 46 | 60 | μA | |
| Accuracy | | | | | | |
| RES | Resolution | — | 16 | — | Bits | |
| INL | Integral Non-Linearity | — | .0038 | — | %FSR | V _{DD} = 2.7V |
| V _{OS} | Offset Error | — | — | ±0.9 | %FSR | IN+, IN- = 0V |
| V _{NOISE} | Referred to input | — | 60 | — | μVrms | |
| CMR | Common Mode Rejection | — | 75 | — | dB | At DC |
| FSE | Full Scale Error | — | 0.4% | — | %FS | |
| PSRR | Power Supply Rejection Ratio | — | 75 | — | dB | V _{DD} = 2.5V to 3.5V |
| INn+ | | | | | | |
| V _{IN} | Input Voltage | — | — | V _{DD} | V | Note 1 |
| | Absolute Voltage Range on INn | GND | — | V _{DD} | V | |
| | Input Bias Current | — | 1 | 100 | nA | |
| C _{IN} | Input Sampling Capacitance | — | 2 | — | pF | |
| R _{IN} | Differential Input Resistance | — | 2.0 | — | MΩ | Note 2 |
| REF_{IN}, REF_{OUT} | | | | | | |
| V _{REF} | REF _{IN} Voltage Range | 0 | — | 1.25 | V | |
| I _{REF} | REF _{IN} Input Current | — | 1 | — | μA | |
| V _{REFOUT} | REF _{OUT} Voltage | — | 1.193 | — | V | |
| REF _{SINK} | REF _{OUT} Current Sink Capability | — | 10 | — | μA | |
| REF _{SRC} | REF _{OUT} Current Source Capability | 300 | — | — | μA | |

- Note**
- 1: Differential input voltage defined as (V_{IN+} – V_{IN-}).
 - 2: Resistance from INn+ to INn- or INn to GND.
 - 3: @ V_{DD} = 1.8V, I_{SOURCE} ≤ 200μA.

TC3404

TC3404 DC ELECTRICAL SPECIFICATIONS (CONTINUED)

Electrical Characteristics: $T_A = 25^\circ\text{C}$ and $V_{DD} = 2.7\text{V}$, unless otherwise specified. **Boldface** type specifications apply for temperatures of 0°C to 85°C . $V_{REF} = 1.25\text{V}$, Internal Clock Frequency = 520kHz.

| Symbol | Parameter | Min | Typ | Max | Unit | Test Conditions |
|-----------------------------|--------------------------------|---------------------------------------|------|---------------------------------------|-----------------------|-------------------------------------------------|
| SCLK, A0, A1, ENABLE | | | | | | |
| V_{IL} | Input Low Voltage | — | — | $0.3 \times V_{DD}$ | V | |
| V_{IH} | Input High Voltage | $0.7 \times V_{DD}$ | — | — | V | |
| I_{LEAK} | Leakage Current | — | 1 | — | μA | |
| SDAT, PFO | | | | | | |
| V_{OL} | Output Low Voltage | — | — | 0.4 | V | $I_{OL} = 1.5\text{mA}$ |
| V_{OH} | Output High Voltage (SDAT) | $0.9 \times V_{DD}$ | — | — | V | $I_{SOURCE} = 400\mu\text{A}$ (Note 3) |
| V_{DDMIN} | Minimum V_{DD} for PFO Valid | — | 1.1 | 1.3 | μA | |
| PFI | | | | | | |
| V_{CCPFI} | PFI Input Voltage Range | 0 | — | V_{DD} | V | |
| | PFI Input Current | -0.1 | .01 | 0.1 | μA | |
| V_{THR} | Threshold (V_{TH} , PFI) | — | 1.23 | — | V | |
| | Threshold Hysteresis | — | 30 | — | mV | |
| | Threshold Tempco | — | 30 | — | ppm/ $^\circ\text{C}$ | |

- Note 1:** Differential input voltage defined as $(V_{IN+} - V_{IN-})$.
Note 2: Resistance from $INn+$ to $INn-$ or INn to GND.
Note 3: @ $V_{DD} = 1.8\text{V}$, $I_{SOURCE} \leq 200\mu\text{A}$.

TC3404 AC ELECTRICAL SPECIFICATIONS

Electrical Characteristics: $T_A = 25^\circ\text{C}$ and $V_{DD} = 2.7\text{V}$, unless otherwise specified. **Boldface** type specifications apply for temperatures of 0°C to 85°C . $V_{REF} = 1.25\text{V}$, Internal Clock Frequency = 520kHz.

| Symbol | Parameter | Min | Typ | Max | Unit | Test Conditions |
|----------|------------------------------------|-------------|------------|-------------|-----------------|---------------------------------------------------------------|
| t_1 | Resolution Reduction Clock Width | 1 | — | — | μsec | Width of SCLK (Negative) |
| t_2 | Resolution Reduction Clock Width | 1 | — | — | μsec | Width of SCLK (Positive) |
| t_3 | Conversion Time (15-bit Plus Sign) | — | 125 | — | msec | 16-bit Conversion, $T_A = 25^\circ\text{C}$ (Note 1) |
| | Conversion Time (14-bit Plus Sign) | — | $t_3/2.0$ | — | msec | 15-bit Conversion |
| | Conversion Time (13-bit Plus Sign) | — | $t_3/4.0$ | — | msec | 14-bit Conversion |
| | Conversion Time (12-bit Plus Sign) | — | $t_3/7.8$ | — | msec | 13-bit Conversion |
| | Conversion Time (11-bit Plus Sign) | — | $t_3/15.1$ | — | msec | 12-bit Conversion |
| | Conversion Time (10-bit Plus Sign) | — | $t_3/28.6$ | — | msec | 11-bit Conversion |
| | Conversion Time (9-bit Plus Sign) | — | $t_3/51.4$ | — | msec | 10-bit Conversion |
| t_4 | Resolution Reduction Window | — | $t_3/85.7$ | — | msec | Width of SCLK |
| t_5 | SCLK to Data Valid | 1000 | — | — | nsec | SCLK Falling Edge to SDAT Valid |
| t_6 | Address Setup | 0 | — | — | nsec | Address Valid to SCLK |
| t_7 | Address Hold | 1000 | — | — | nsec | SCLK to Address Valid Hold |
| t_8 | Acknowledge Delay | — | — | 1000 | nsec | SCLK to SDAT Delay |
| t_{11} | RESET Delay | 5 | — | 64 | μsec | Delay V_{TH} Falling at 10V/msec to RESET Low |

- Note 1:** Nominal temperature drift is $-2830\text{ppm}/^\circ\text{C}$ for temperature less than 25°C and $-1340\text{ppm}/^\circ\text{C}$ for temperatures greater than 25°C .

2.0 PIN DESCRIPTIONS

The descriptions of the pins are listed in Table 2-1.

TABLE 2-1: PIN FUNCTION TABLE

| Pin No. (16-Pin PDIP (16-Pin QSOP)) | Symbol | Description |
|-------------------------------------------|--------------------|---------------------------------------------------------------------------------------------------------------------------------------------------------------------------------------------------------------------------------------------------------------------------------------------------------------------------------------------------------------------------------------------------------------------|
| 1 | IN1+ | Analog Input. This is the positive terminal of a true differential input with the negative input tied internally to GND. See Section 1.0, Electrical Characteristics. |
| 2 | IN2+ | Analog Input. This is the positive terminal of a true differential input with the negative input tied internally to GND. See Section 1.0, Electrical Characteristics. |
| 3 | IN3+ | Analog Input. This is the positive terminal of a true differential input consisting of IN3+ and IN3-. $V_{IN3} = (IN3+ - IN3-)$. See Section 1.0, Electrical Characteristics. |
| 4 | IN3- | Analog Input. This is the negative terminal of a true differential input consisting of IN3+ and IN3-. $V_{IN3} = (IN3+ - IN3-)$ IN3- can swing to, but not below, ground. See Section 1.0, Electrical Characteristics. |
| 5 | IN4+ | Analog Input. This is the positive terminal of a true differential input consisting of IN4+ and IN4-. $V_{IN4} = (IN4+ - IN4-)$. See Section 1.0, Electrical Characteristics. |
| 6 | IN4- | Analog Input. This is the negative terminal of a true differential input consisting of IN4+ and IN4-. $V_{IN4} = (IN4+ - IN4-)$ IN4- can swing to, but not below, ground. See Section 1.0, Electrical Characteristics. |
| 7 | REF _{IN} | Analog Input. The converter's reference voltage is the differential between this pin and ground times two. It may be tied directly to REF _{OUT} or scaled using a resistor divider. Any user supplied reference voltage less than 1.25 may be used in place of REF _{OUT} . |
| 8 | GND | Ground Terminal. |
| 9 | REF _{OUT} | Analog Output. The internal reference connects to this pin. It may be scaled externally, and tied to the REF _{IN} input to provide the converter's reference voltage. Care must be taken in connecting external circuitry to this pin. This pin is in a high impedance state during Sleep mode. See Section 1.0, Electrical Characteristics. |
| 10 | SDAT | Digital Output (push-pull). This is the microPort™ serial data output. SDAT is driven low while the TC3404 is converting data, effectively providing a "busy" signal. After the conversion is complete, every high to low transition on the SCLK pin puts a bit from the resulting data word on the SDAT pin (from MSB to LSB). |
| 11 | PFO | Digital Output (open drain). This is the output of the internal threshold detector. When PFI is less than the internal reference, PFO is driven low. |
| 12 | PFI | Analog Input. This is the positive input to an internal comparator used as a threshold detector. The negative input is tied to an internal reference. |
| 13 | A1 | Digital Input. Controls analog multiplexer in conjunction with A0 to select one of the four Input channels. This address is latched at the falling edge of the SCLK, which starts an A/D conversion. A1, A0 = 00 = Input 1; 01 = Input 2; 10 = Input 3; 11 = Input 4. |
| 14 | A0 | Digital Input. Controls analog multiplexer in conjunction with A1 to select one of four Input channels. This address is latched at the falling edge of the SCLK, which starts an A/D conversion. A1, A0 = 00 = Input 1; 01 = Input 2; 10 = Input 3; 11 = Input 4. |
| 15 | SCLK | Digital Input. This is the microPort™ serial clock input. The TC3404 comes out of Sleep mode and a conversion cycle begins when this pin is driven low. After the conversion starts, each additional falling edge (up to six) detected on SCLK for t_4 seconds reduces the A/D resolution by one bit. When the conversion is complete, the data word can be shifted out on the SDAT pin by clocking the SCLK pin. |
| 16 | V _{DD} | Power Supply Input. |

3.0 DETAILED DESCRIPTION

The TC3404 has a 16-bit sigma-delta A/D converter. It has two differential single-ended inputs, an analog multiplexer and an early warning Power Fail detector. See the Typical Application circuit and the Functional Block diagram. The key components of the TC3404 are described below.

Also refer to Figure 3-5, A/D Operational Flowchart and the Timing Diagrams, Figure 3-1, Figure 3-2 and Figure 3-3.

3.1 A/D Converter Operation

When the TC3404 is not converting, it is in Sleep mode with both the SCLK and SDAT lines high. An A/D conversion is initiated by a high to low transition on the SCLK line at which time the internal clock of the TC3404 is started and the address value (A0 and A1) is internally latched. The address value steers the analog multiplexer to select the input channel to be converted. Each additional high to low transition of SCLK (following the initial SCLK falling edge) during the time interval t_4 , will decrement the conversion resolution by one bit and reduce the conversion time by one half. The time interval t_4 is referred to as the resolution reduction window. The minimum conversion resolution is 10-bits so any more than 6 SCLK transitions during t_4 will be ignored.

After each high to low transition of SCLK, in the t_4 interval, the SDAT output is driven high by the TC3404 to acknowledge that the resolution has been decremented. When the SCLK returns high or the t_4 interval ends, the SDAT line returns low (see Figure 3-2). When the conversion is complete SDAT is driven high. The TC3404 now enters Sleep mode and the conversion value can be read as a serial data word on the SDAT line.

3.2 Reading the Data Word

After the conversion is complete and SDAT goes high, the conversion value can be clocked serially onto the SDAT line by high to low transitions of the SCLK. The data word is in two's complement format with the sign bit clocked onto the SDAT line, first followed by the MSB and ending in the LSB. For a 16-bit conversion the data word would consist of a sign bit followed by 15 magnitude bits, Table 3-1 shows the data word versus input voltage for a 16-bit conversion. Note that the full scale input voltage range is $\pm(2 \text{ REF}_{\text{IN}} - 1\text{LSB})$. When REF_{OUT} is fed back directly to REF_{IN} , an LSB is $73\mu\text{V}$ for a 16-bit conversion, as REF_{OUT} is typically 1.193V.

Figure 3-4 shows typical SCLK and SDAT waveforms for 16, 12 and 10-bit conversions. Note that any complete convert and read cycle requires 17 negative edge clock pulses. The first is the convert command. Then, up to six of these can occur in the resolution reduction window, t_4 , to decrement resolution. The remaining pulses clock out the conversion data word.

TABLE 3-1: DATA CONVERSION WORD VS. VOLTAGE INPUT ($\text{REF}_{\text{IN}} = 1.193\text{V}$)

| Data Word | INn+ – INn- (Volts) |
|---------------------|--------------------------------|
| 0111 1111 1111 1111 | 2.38596 (Positive Full Scale) |
| 0000 0000 0000 0001 | 72.8 E -6 |
| 0000 0000 0000 0000 | 0 |
| 1111 1111 1111 1111 | -72.8 E -6 |
| 1000 0000 0000 0001 | -2.38596 (Negative Full Scale) |
| 1000 0000 0000 0000 | Reserved Code |

The SCLK input has a filter which rejects any positive or negative pulse of width less than 50nsec to reduce noise. The rejection width of this pulse can vary between 50nsec and 750nsec depending on processing parameters and supply voltage.

Figure 3-1 and Table 3-2 show information for determining the mode of operation for the TC3404 by recording the value of SDAT for SCLK in a high, then low, then high state. For example, if SCLK goes through a 1-0-1 transition and the corresponding values of SDAT are 1-1-0, then the SCLK falling edge started a new data conversion. A 0-1-0 for SDAT would have indicated a resolution reduction had occurred. This is useful if the microcontroller has a Watchdog Reset or otherwise loses track of where the TC3404 is in the conversion and data readout sequence. The microcontroller can simply transition SCLK until it "finds" a Start Conversion condition.

FIGURE 3-1: SCLK, SDAT LOGIC STATE DIAGRAM

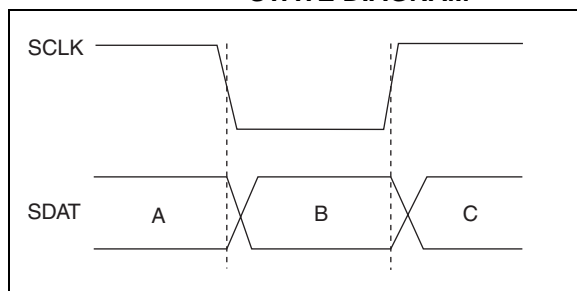

TABLE 3-2: SCLK, SDAT LOGIC STATE

| A | B | C | Status |
|---|---|---|------------------------|
| 1 | 1 | 0 | Start Conversion |
| 0 | 1 | 0 | Resolution Reduction |
| x | 1 | 1 | Data Transfer |
| x | 0 | 0 | Data Transfer or Busy* |

***Note:** The code X00 has a dual meaning: Data Transfer or Busy converting. To avoid confusion, the user should send only the required number of pulses for the desired resolution, then wait for SDAT to rise to 1, indicating conversion is complete before clocking SCLK again to read out data bits.

FIGURE 3-2: CONVERSION AND DATA OUTPUT TIMING

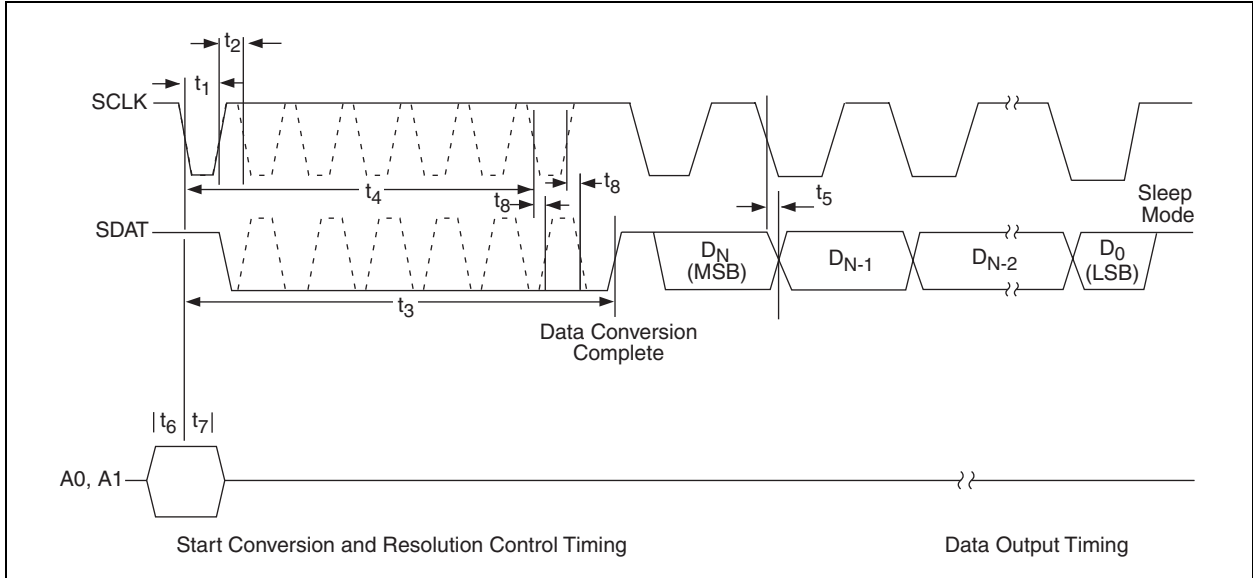

FIGURE 3-3: RESET AND POWER FAIL TIMING

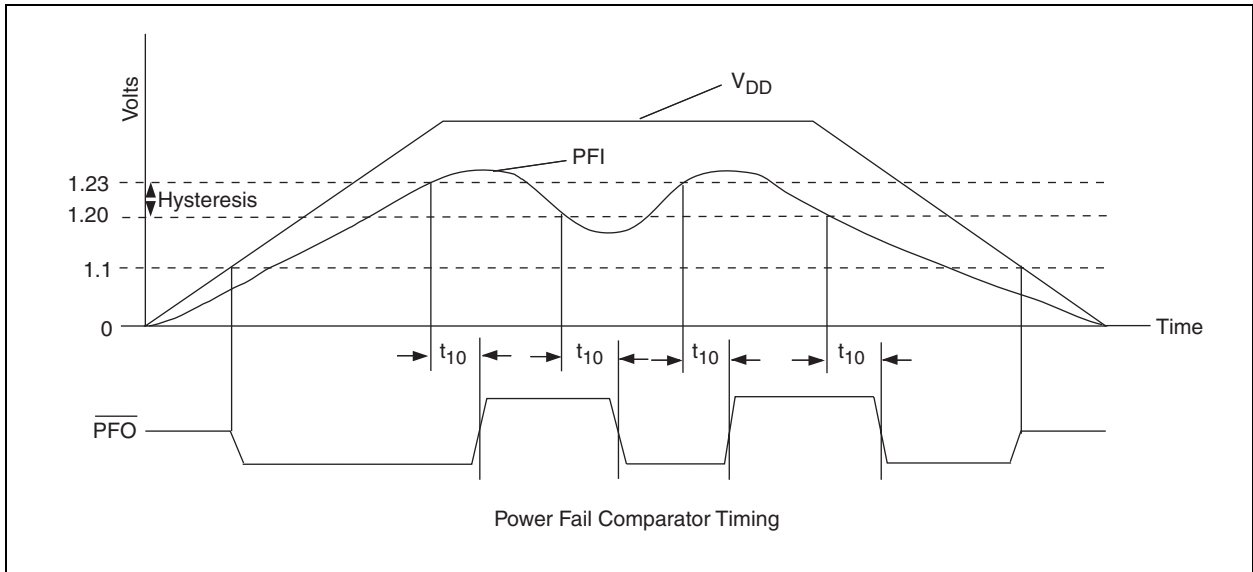

FIGURE 3-4: SCLK AND SDAT WAVEFORMS FOR 16, 12 AND 10-BIT CONVERSIONS

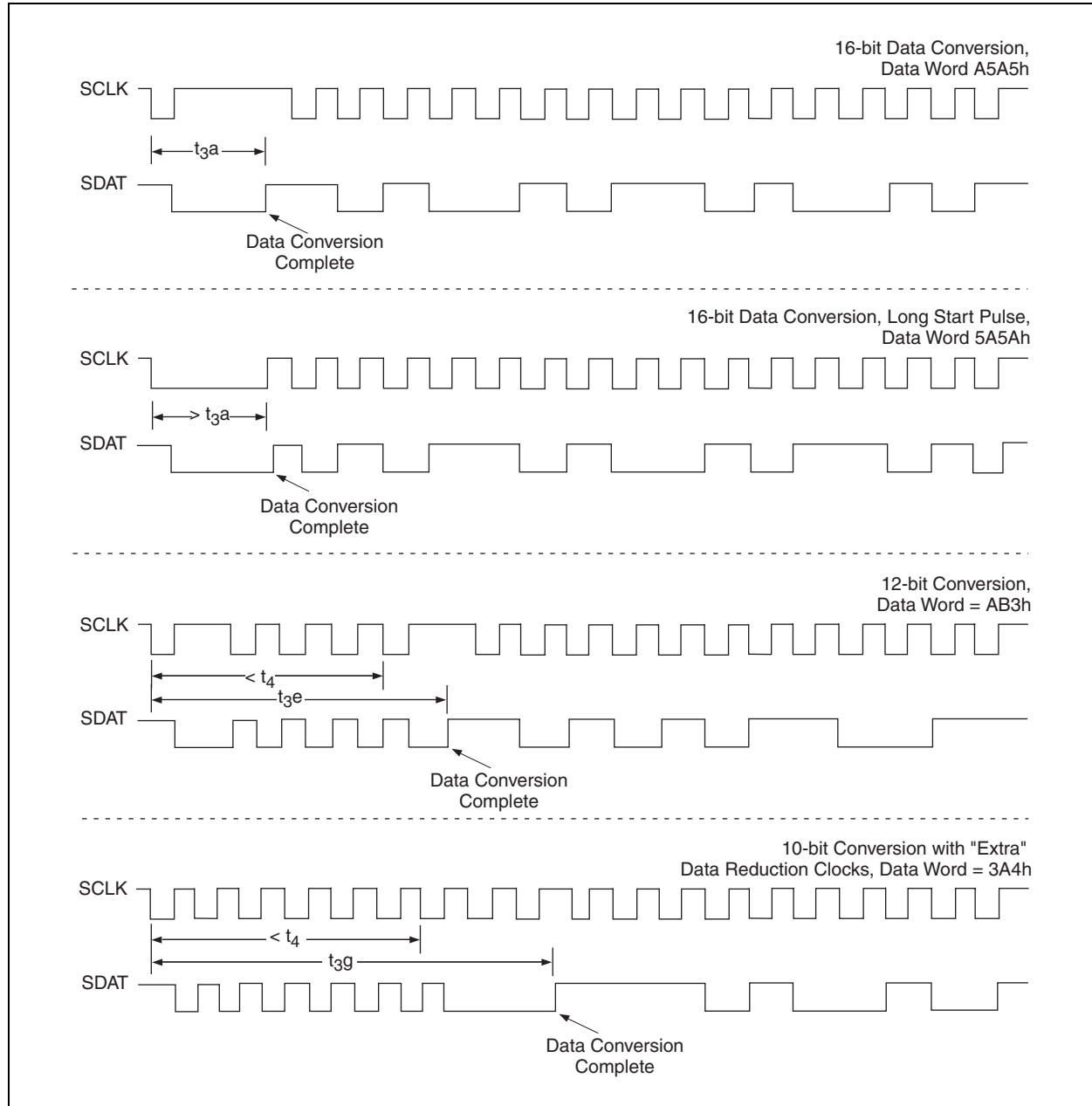
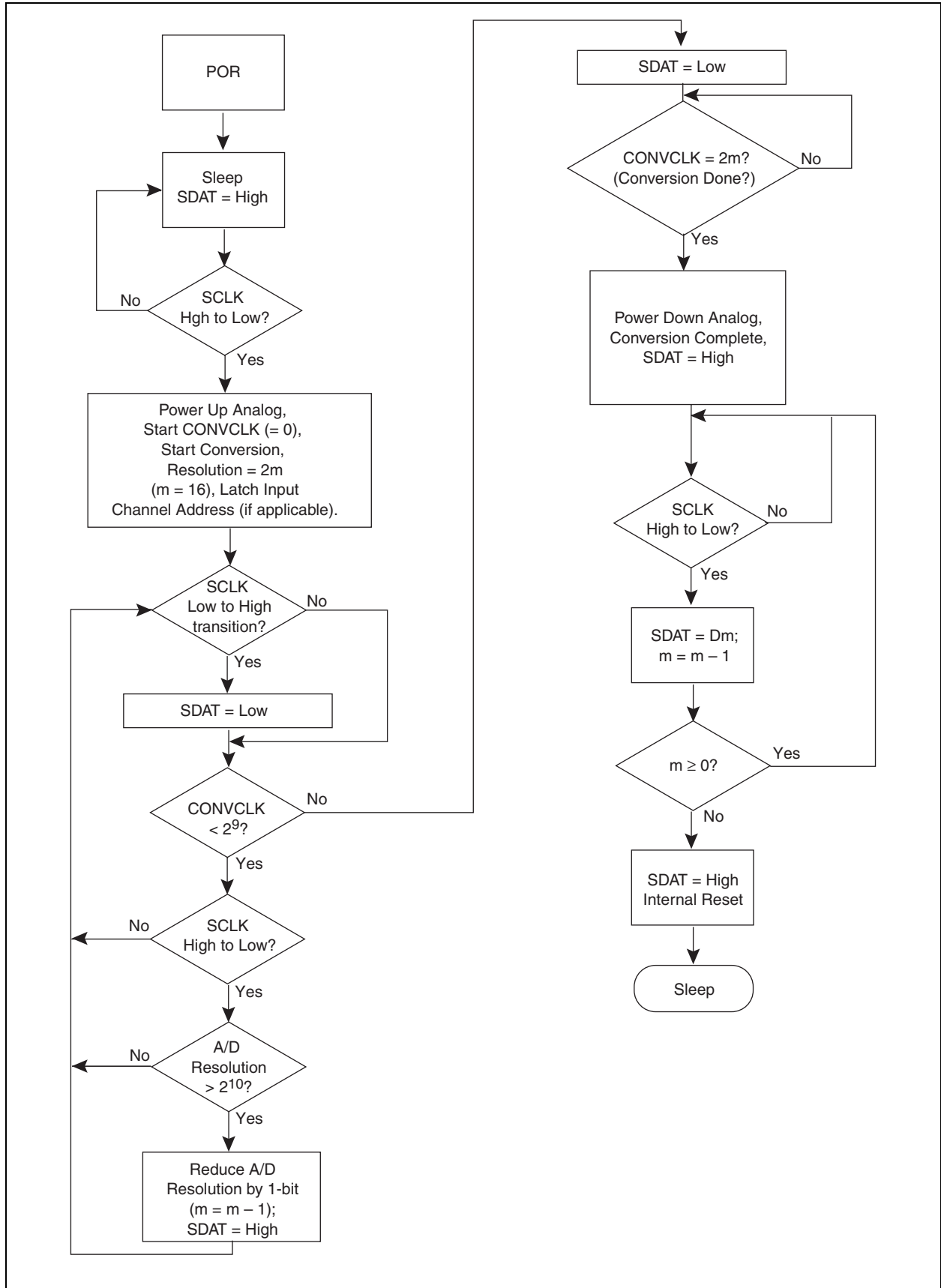

FIGURE 3-5: A/D OPERATIONAL FLOWCHART



3.3 Power Fail Detector

The Power Fail detector is a comparator in which the inverting input is connected to the internal voltage reference. The non-inverting input is the PFI pin of the TC3404 and the $\overline{\text{PFO}}$ pin is the active low, open drain output. This comparator is suitable as an early warning fail or low battery indicator. In a typical application, where a voltage regulator is being used to supply power to a system, the Power Fail comparator would monitor the input voltage to the regulator while the V_{DD} monitor would measure the output voltage of the regulator. Both $\overline{\text{PFO}}$ and $\overline{\text{RESET}}$ would drive interrupt pins of a microcontroller.

The Power Fail detector may be used as a Wake-up or Watchdog Timer. The Typical Application circuit shows an RC network on PFI with the capacitor tied to a tristated μC I/O pin. If R_4 is $1\text{ M}\Omega$ and C_2 is $10\mu\text{F}$, the time constant is roughly ten seconds. The μC resets the RC network by driving the I/O tied to PFI low and then tristating it. The RC network will ramp to 1.23V in roughly 9 seconds, assuming a V_{BATT} of 3.0V . With $\overline{\text{PFO}}$ tied to a μC input or interrupt, the μC will see a low to high transition on $\overline{\text{PFO}}$ when the voltage on PFI exceeds 1.23V . The $\overline{\text{PFO}}$ output is specified to be valid for $V_{\text{DD}} = 1.3$ to 5.5V .

4.0 PACKAGING INFORMATION

4.1 Package Marking Information

Package marking data not available at this time.

4.2 Taping Forms

Component Taping Orientation for 16-Pin QSOP (Narrow) Devices

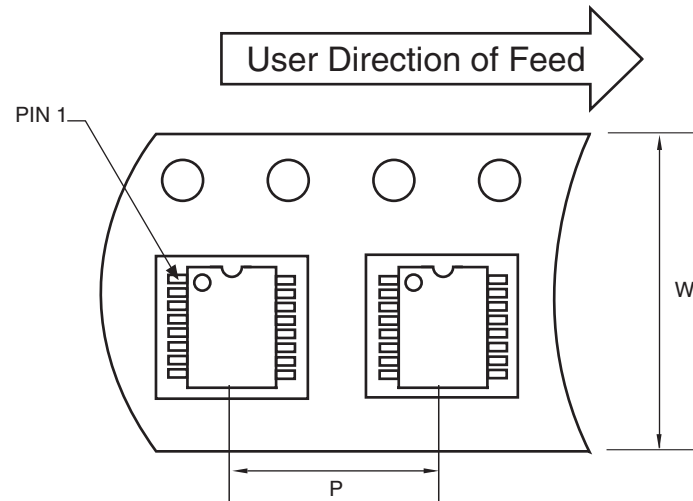

Standard Reel Component Orientation
for TR Suffix Device

Carrier Tape, Reel Size, Number of Components Per Reel and Reel Size

| Package | Carrier Width (W) | Pitch (P) | Part Per Full Reel | Reel Size |
|-----------------|-------------------|-----------|--------------------|-----------|
| 16-Pin QSOP (N) | 12 mm | 8 mm | 2500 | 13 in |

TC3404

4.3 Package Dimensions

16-Pin PDIP (Narrow)

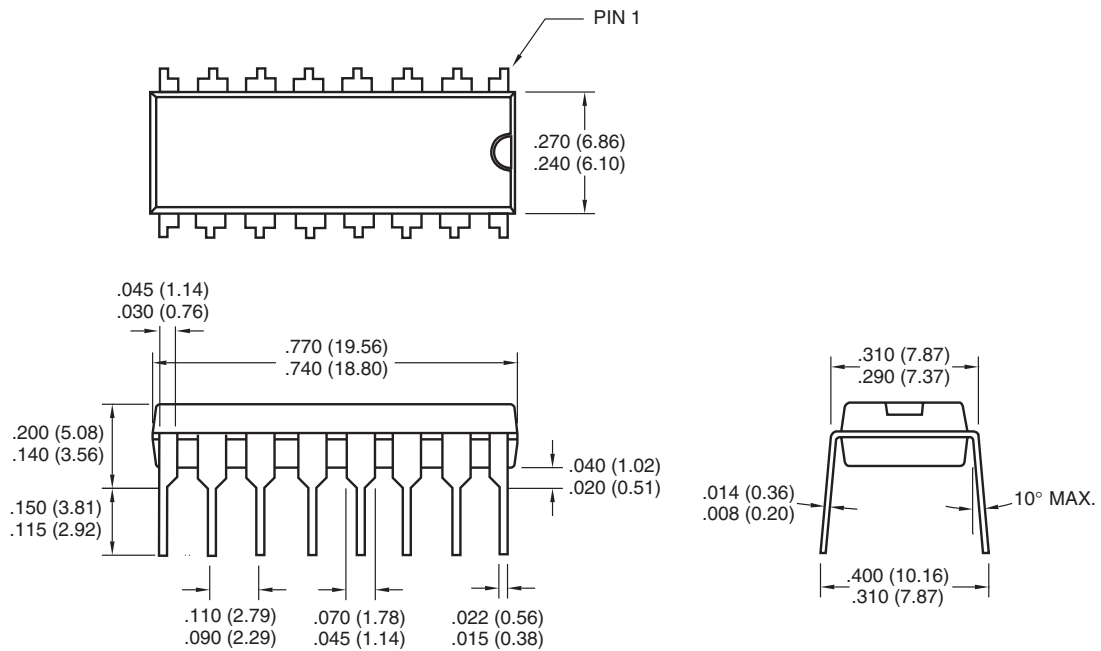

Dimensions: inches (mm)

16-Pin QSOP (Narrow)

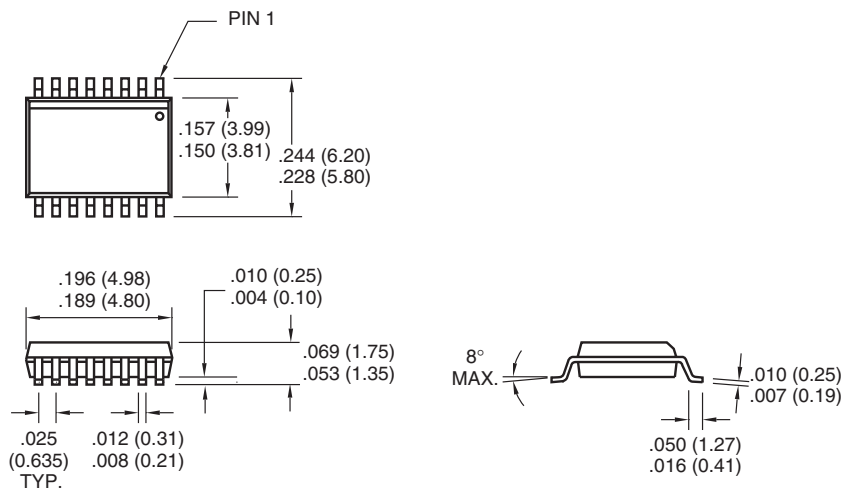

Dimensions: inches (mm)

SALES AND SUPPORT

Data Sheets

Products supported by a preliminary Data Sheet may have an errata sheet describing minor operational differences and recommended workarounds. To determine if an errata sheet exists for a particular device, please contact one of the following:

1. Your local Microchip sales office
2. The Microchip Corporate Literature Center U.S. FAX: (480) 792-7277
3. The Microchip Worldwide Site (www.microchip.com)

Please specify which device, revision of silicon and Data Sheet (include Literature #) you are using.

New Customer Notification System

Register on our web site (www.microchip.com/cn) to receive the most current information on our products.

TC3404

NOTES:

Note the following details of the code protection feature on Microchip devices:

- Microchip products meet the specification contained in their particular Microchip Data Sheet.
- Microchip believes that its family of products is one of the most secure families of its kind on the market today, when used in the intended manner and under normal conditions.
- There are dishonest and possibly illegal methods used to breach the code protection feature. All of these methods, to our knowledge, require using the Microchip products in a manner outside the operating specifications contained in Microchip's Data Sheets. Most likely, the person doing so is engaged in theft of intellectual property.
- Microchip is willing to work with the customer who is concerned about the integrity of their code.
- Neither Microchip nor any other semiconductor manufacturer can guarantee the security of their code. Code protection does not mean that we are guaranteeing the product as "unbreakable."

Code protection is constantly evolving. We at Microchip are committed to continuously improving the code protection features of our products. Attempts to break Microchip's code protection feature may be a violation of the Digital Millennium Copyright Act. If such acts allow unauthorized access to your software or other copyrighted work, you may have a right to sue for relief under that Act.

Information contained in this publication regarding device applications and the like is provided only for your convenience and may be superseded by updates. It is your responsibility to ensure that your application meets with your specifications. MICROCHIP MAKES NO REPRESENTATIONS OR WARRANTIES OF ANY KIND WHETHER EXPRESS OR IMPLIED, WRITTEN OR ORAL, STATUTORY OR OTHERWISE, RELATED TO THE INFORMATION, INCLUDING BUT NOT LIMITED TO ITS CONDITION, QUALITY, PERFORMANCE, MERCHANTABILITY OR FITNESS FOR PURPOSE. Microchip disclaims all liability arising from this information and its use. Use of Microchip's products as critical components in life support systems is not authorized except with express written approval by Microchip. No licenses are conveyed, implicitly or otherwise, under any Microchip intellectual property rights.

Trademarks

The Microchip name and logo, the Microchip logo, Accuron, dsPIC, KEELoQ, microID, MPLAB, PIC, PICmicro, PICSTART, PRO MATE, PowerSmart, rPIC, and SmartShunt are registered trademarks of Microchip Technology Incorporated in the U.S.A. and other countries.

AmpLab, FilterLab, Migratable Memory, MXDEV, MXLAB, PICMASTER, SEEVAL, SmartSensor and The Embedded Control Solutions Company are registered trademarks of Microchip Technology Incorporated in the U.S.A.

Analog-for-the-Digital Age, Application Maestro, dsPICDEM, dsPICDEM.net, dsPICworks, ECAN, ECONOMONITOR, FanSense, FlexROM, fuzzyLAB, In-Circuit Serial Programming, ICSP, ICEPIC, Linear Active Thermistor, MPASM, MPLIB, MPLINK, MPSIM, PICkit, PICDEM, PICDEM.net, PICLAB, PICtail, PowerCal, PowerInfo, PowerMate, PowerTool, rLAB, rPICDEM, Select Mode, Smart Serial, SmartTel, Total Endurance and WiperLock are trademarks of Microchip Technology Incorporated in the U.S.A. and other countries.

SQTP is a service mark of Microchip Technology Incorporated in the U.S.A.

All other trademarks mentioned herein are property of their respective companies.

© 2005, Microchip Technology Incorporated, Printed in the U.S.A., All Rights Reserved.

 Printed on recycled paper.

**QUALITY MANAGEMENT SYSTEM
CERTIFIED BY DNV
== ISO/TS 16949:2002 ==**

Microchip received ISO/TS-16949:2002 quality system certification for its worldwide headquarters, design and wafer fabrication facilities in Chandler and Tempe, Arizona and Mountain View, California in October 2003. The Company's quality system processes and procedures are for its PICmicro® 8-bit MCUs, KEELoQ® code hopping devices, Serial EEPROMs, microperipherals, nonvolatile memory and analog products. In addition, Microchip's quality system for the design and manufacture of development systems is ISO 9001:2000 certified.



WORLDWIDE SALES AND SERVICE

AMERICAS

Corporate Office
2355 West Chandler Blvd.
Chandler, AZ 85224-6199
Tel: 480-792-7200
Fax: 480-792-7277
Technical Support:
<http://support.microchip.com>
Web Address:
www.microchip.com

Atlanta
Alpharetta, GA
Tel: 770-640-0034
Fax: 770-640-0307

Boston
Westborough, MA
Tel: 774-760-0087
Fax: 774-760-0088

Chicago
Itasca, IL
Tel: 630-285-0071
Fax: 630-285-0075

Dallas
Addison, TX
Tel: 972-818-7423
Fax: 972-818-2924

Detroit
Farmington Hills, MI
Tel: 248-538-2250
Fax: 248-538-2260

Kokomo
Kokomo, IN
Tel: 765-864-8360
Fax: 765-864-8387

Los Angeles
Mission Viejo, CA
Tel: 949-462-9523
Fax: 949-462-9608

San Jose
Mountain View, CA
Tel: 650-215-1444
Fax: 650-961-0286

Toronto
Mississauga, Ontario,
Canada
Tel: 905-673-0699
Fax: 905-673-6509

ASIA/PACIFIC

Australia - Sydney
Tel: 61-2-9868-6733
Fax: 61-2-9868-6755

China - Beijing
Tel: 86-10-8528-2100
Fax: 86-10-8528-2104

China - Chengdu
Tel: 86-28-8676-6200
Fax: 86-28-8676-6599

China - Fuzhou
Tel: 86-591-8750-3506
Fax: 86-591-8750-3521

China - Hong Kong SAR
Tel: 852-2401-1200
Fax: 852-2401-3431

China - Qingdao
Tel: 86-532-8502-7355
Fax: 86-532-8502-7205

China - Shanghai
Tel: 86-21-5407-5533
Fax: 86-21-5407-5066

China - Shenyang
Tel: 86-24-2334-2829
Fax: 86-24-2334-2393

China - Shenzhen
Tel: 86-755-8203-2660
Fax: 86-755-8203-1760

China - Shunde
Tel: 86-757-2839-5507
Fax: 86-757-2839-5571

China - Wuhan
Tel: 86-27-5980-5300
Fax: 86-27-5980-5118

China - Xian
Tel: 86-29-8833-7250
Fax: 86-29-8833-7256

ASIA/PACIFIC

India - Bangalore
Tel: 91-80-2229-0061
Fax: 91-80-2229-0062

India - New Delhi
Tel: 91-11-5160-8631
Fax: 91-11-5160-8632

India - Pune
Tel: 91-20-2566-1512
Fax: 91-20-2566-1513

Japan - Yokohama
Tel: 81-45-471-6166
Fax: 81-45-471-6122

Korea - Gumi
Tel: 82-54-473-4301
Fax: 82-54-473-4302

Korea - Seoul
Tel: 82-2-554-7200
Fax: 82-2-558-5932 or
82-2-558-5934

Malaysia - Penang
Tel: 60-4-646-8870
Fax: 60-4-646-5086

Philippines - Manila
Tel: 63-2-634-9065
Fax: 63-2-634-9069

Singapore
Tel: 65-6334-8870
Fax: 65-6334-8850

Taiwan - Hsin Chu
Tel: 886-3-572-9526
Fax: 886-3-572-6459

Taiwan - Kaohsiung
Tel: 886-7-536-4818
Fax: 886-7-536-4803

Taiwan - Taipei
Tel: 886-2-2500-6610
Fax: 886-2-2508-0102

Thailand - Bangkok
Tel: 66-2-694-1351
Fax: 66-2-694-1350

EUROPE

Austria - Wels
Tel: 43-7242-2244-399
Fax: 43-7242-2244-393

Denmark - Copenhagen
Tel: 45-4450-2828
Fax: 45-4485-2829

France - Paris
Tel: 33-1-69-53-63-20
Fax: 33-1-69-30-90-79

Germany - Munich
Tel: 49-89-627-144-0
Fax: 49-89-627-144-44

Italy - Milan
Tel: 39-0331-742611
Fax: 39-0331-466781

Netherlands - Drunen
Tel: 31-416-690399
Fax: 31-416-690340

Spain - Madrid
Tel: 34-91-708-08-90
Fax: 34-91-708-08-91

UK - Wokingham
Tel: 44-118-921-5869
Fax: 44-118-921-5820